



Maintenance-free  
AGM TPPL  
Rechargeable VRLA  
battery for military  
applications

UK6TNMF



**THE HAWKER ARMASAFE  
PLUS BATTERY  
KEEPS YOUR  
ARMY ON THE MOVE**

**ARMASAFE**  
*plus*



The **ARMASAFE Plus** series utilises the proven EnerSys® Thin Plate Pure Lead valve regulated technology, to meet the diverse and demanding energy storage needs of the modern world. Today over 2 million batteries have been installed on a wide range of combat and tactical vehicles throughout the world.

EnerSys TPPL technology packs more power into the same space as a conventional battery, as well as reducing the corrosion and water losses through the purity of the materials used in construction, providing extended storage and service life as well as increasing the resistance to abusive deep discharges.

The inherent design of the VRLA Armasafe battery minimises gas evolution and eliminates the need to top up periodically with water. The electrolyte is fully absorbed into the glass mat separators between the positive and negative plates, which mean there is no free acid within the battery case; this gives increased flexibility in mounting position.



# UK6TNMF

Part number: 9750N7000  
NSN: Z9BAT / 6140-99-219-2903



## SPECIFICATIONS:

### Technical Data:

Technology	*TPPL / *AGM / *VRLA
Nominal Voltage	12 V
Charging Voltage	14.4 V @ 20 °C
Float Voltage	13.74 V @ 20 °C
**Nominal Capacity C <sub>20</sub>	126 Ah
**Nominal Capacity C <sub>10</sub>	114 Ah
**Nominal Capacity C <sub>5</sub>	103 Ah
**Nominal Capacity C <sub>1</sub>	80 Ah
Reserve Capacity	240 Min
CCA (S.A.E.)	1225 A
Internal Resistance	1.6 mΩ
Temperature Performance Range	-40°C to +80°C
Cycle life at 20% of DoD	3500 Cycles
Cycle life at 50% of DoD	1650 Cycles
Cycle life at 80% of DoD	680 Cycles
Weight	40 kg
Storage	60 Months
Storage at 25°C without recharge	30 Months
Terminals	EN50342-2

\*TPPL: Thin Plate Pure Lead  
\*AGM: Absorbed Glass Mat  
\*VRLA: Valve Regulated Lead Acid  
\*\*In accordance with EN50342-1/2006

### Features & Benefits:

Fully compliant with UK MoD specification Defence Standard 61-21 Supplement 042-Issue 3

- Installation orientation: can be mounted in any orientation except inverted
- Recombination efficiency 99%
- Integrated flame arresters - Protection against flame transmission
- UN Transportation classification UN2800-Class 8 exempt
- 97% Recyclability
- Flame retardency UL94 V-2
- Shock resistant
- Maintenance-free
- Long shelf life
- Resistant to abusive discharges
- Superior cold cranking performance
- Excellent cyclic capability
- Superb charge acceptance

The standard for UK Military Vehicles.

### Dimensions:

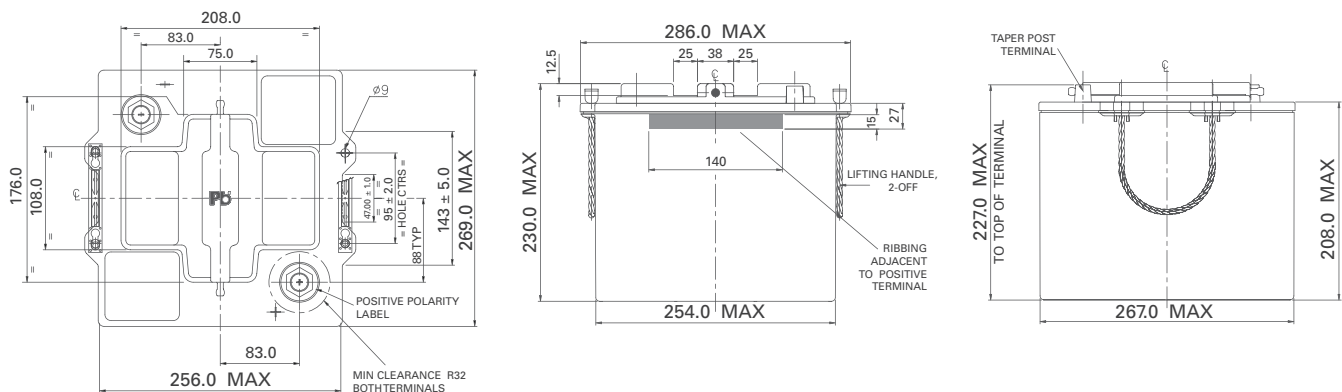

EnerSys EMEA Headquarter  
**EH Europe GmbH**  
Löwenstrasse 32  
8001 Zürich  
Switzerland

For enquiries please contact:  
Tel: +48 33 822 53 91  
Fax: +48 33 822 52 09  
AandD.Sales@ch.enersys.com

Contact: